

Spread Spectrum Clock Generator WAYCOI7368AG08CR

■ DESCRIPTION

WAYCOI7368AG08CR is a clock generator for EMI (Electro Magnetic Interference) reduction. The peak of unnecessary (EMI) can be attenuated by making the oscillation frequency slightly modulate periodically with the internal modulator. WAYCOI7368AG08CR accepts an input clock either from a fundamental Crystal or from an external reference and locks on to it delivering a 1x modulated clock output.

■ FEATURE

- Power down pin : 50 μ A (Max) consumption current at power down
- Input frequency : 12.0 MHz to 55.0 MHz
- Output frequency : 12.0 MHz to 55.0 MHz (One-fold input frequency)
- Analog Spreading Range Selection
- Modulation clock output Duty : 45% to 55%
- Modulation clock Cycle-Cycle Jitter : Less than 250 ps
- Power supply voltage : 2.5V--3.3 V
- Package : 8-pin TDFN
- Operating temperature : - 40 $^{\circ}$ C to + 85 $^{\circ}$ C

■ Application

WAYCOI7368AG08CR is targeted for consumer electronics application such as MFP, STB, DSC, MID,HDMI,LCD panel Camcorder,and other timing sensitive analog video imaging applications Applications of HDMI, RJ45 port has good compatibility

■ BLOCK DIAGRAM

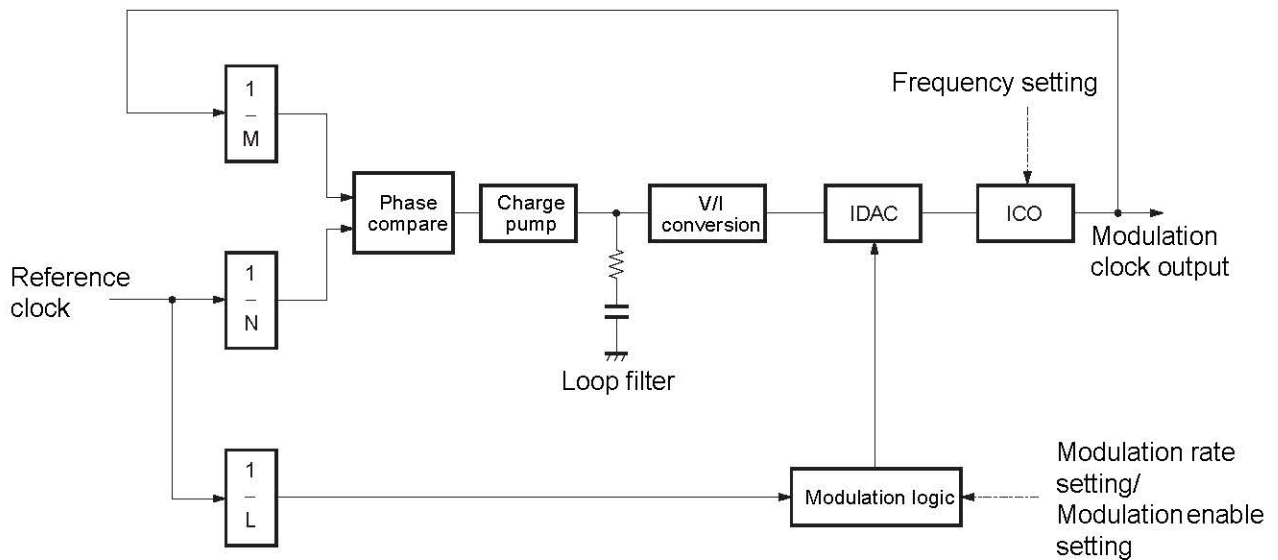
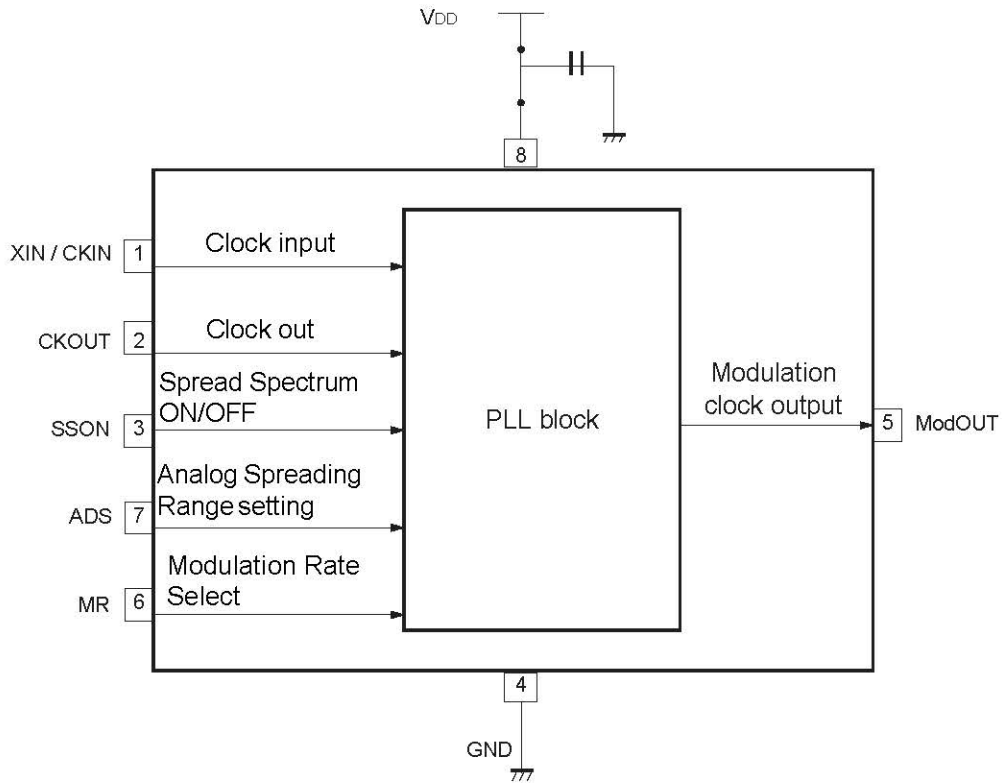

WAYCOI7368AG08CR PLL block

A glitchless IDAC (current output D/A converter) provides precise modulation, thereby dramatically reducing EMI.

■ PIN ASSIGNMENT

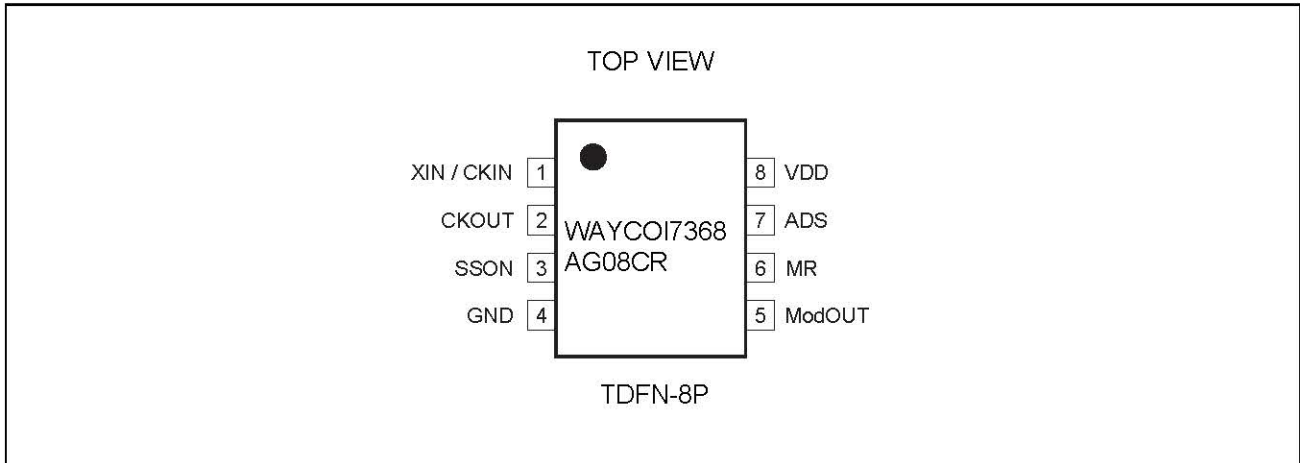

■ PIN DESCRIPTION

Pin name	I/O	Pin no.	Description
XIN / CKIN	I	1	Clock input pin (or External reference clock input).
CKOUT	I	2	Crystal connection(external reference, this pin should be left open)
SSON	I	3	Spread Spectrum ON/OFF. Spread Spectrum function enabled when HIGH, disabled when LOW. Has an internal pull-up resistor.
GND	---	4	GND pin
ModOUT	O	5	Modulation clock output
MR	I	6	Modulation Rate Select. When LOW selects Low Modulation Rate. Selects High Modulation Rate when pulled HIGH. Has an internal pull-up resistor.
ADS	I	7	Spreading Range Selection through external resistor to GND.
VDD	---	8	Power supply voltage pin

■ PIN SETTING

When changing the pin setting, the stabilization wait time for the modulation clock required. The stabilization wait time for the modulation clock takes the maximum value of Lock-Up time in "■ ELECTRICAL CHARACTERISTICS".

ADS modulation enable setting

Resistance(K ohm)	Spreading Range(+/-%)
0-800K	2.5 - 0.01

Note : Analog Spreading Range Selection through external resistor to GND.
Spectrum is spread (modulated) by centering on the input frequency.

Spreading Range vs ADS Resistance Chart

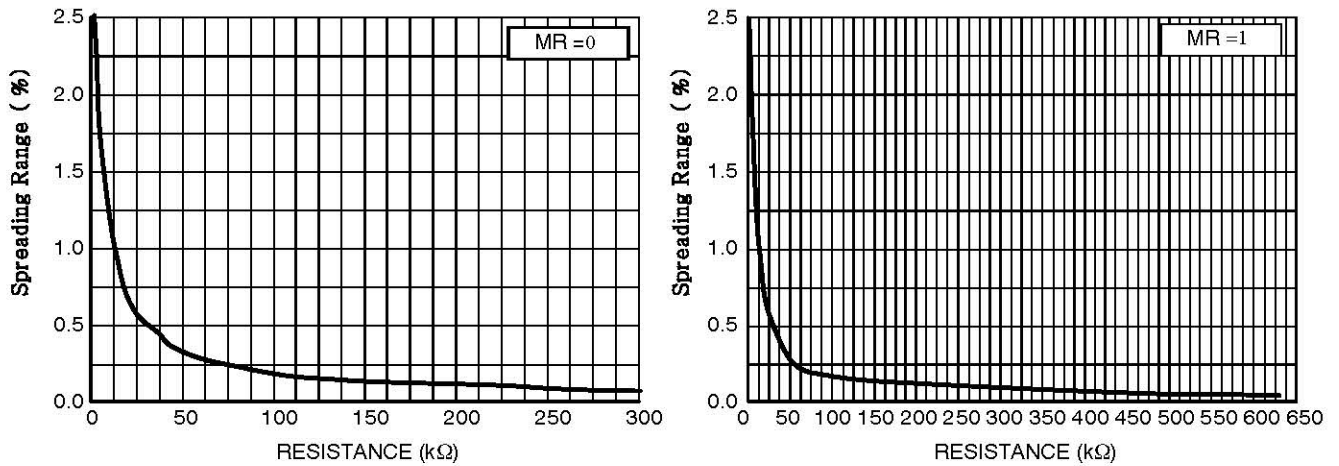

■ TYPICAL CRYSTAL SPECIFICATIONS

FUNDAMENTAL AT CUT PARALLEL RESONANT CRYSTAL

Nominal frequency	27 MHz
Frequency tolerance	± 50 ppm or better at 25°C
Operating temperature range	-25°C to +85°C
Storage temperature	-40°C to +85°C
Load capacitance (C _p)	18 pF
Shunt capacitance	7 pF maximum
ESR	25

■ ABSOLUTE MAXIMUM RATINGS

Parameter	Symbol	Rating		Unit
		Min	Max	
Power supply voltage*	V_{DD}	- 0.5	+ 4.0	V
Input voltage*	V_I	$V_{SS} - 0.5$	$V_{DD} + 0.5$	V
Output voltage*	V_O	$V_{SS} - 0.5$	$V_{DD} + 0.5$	V
Storage temperature	T_{ST}	- 55	+ 125	°C
Operation junction temperature	T_J	- 40	+ 85	°C
Output current	I_O	4	8	mA
Junction Temperature	T_J	—	150	°C
Static Discharge Voltage	T_{DV}	—	1500	V
Overshoot	V_{IOVER}	—	$V_{DD} + 1.0$ ($t_{OVER} \leq 4$ ns)	V
Undershoot	V_{IUNDER}	$V_{SS} - 1.0$ ($t_{UNDER} \leq 4$ ns)	—	V

* : The parameter is based on $V_{SS} = 0.0$ V.

WARNING: Semiconductor devices can be permanently damaged by application of stress (voltage, current, temperature, etc.) in excess of absolute maximum ratings. Do not exceed these ratings.

Overshoot/Undershoot

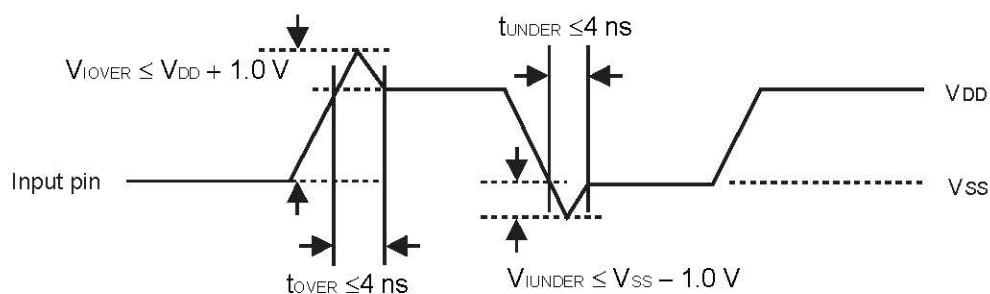

■ ELECTRICAL CHARACTERISTICS

• DC Characteristics

(Ta = - 40 °C to + 85 °C, V_{DD} = 3.3 V ± 0.3 V, V_{SS} = 0.0 V)

Parameter	Symbol	Pin	Conditions	Value			Unit
				Min	Typ	Max	
Output voltage	V _{OH}	ModOUT	"H" level output I _{OH} = - 8 mA	2.4	—	—	V
	V _{OL}	ModOUT	"L" level output I _{OL} = 8 mA	—	—	0.4	V
Output impedance	Z _o	ModOUT	12 MHz to 55 MHz	—	30	—	Ω
Input capacitance	C _{IN}	XIN / CKIN	12MHz to 55 MHz	—	—	7	pF
Load capacitance	C _L	ModOUT	12MHz to 55 MHz	—	—	10	pF
Supply Voltage	V _{DD}	V _{DD}		3.0	3.3	3.6	
Power supply current	I _{CC}	V _{DD}	No load capacitance at 27 MHz output	—	—	10	mA
Power down current	I _{pd}	V _{DD}	Input clock stopping	—	—	50	μA

• SWITCHING CHARACTERISTICS

(Ta = - 40 °C to + 85 °C, V_{DD} = 3.3 V ± 0.3 V, V_{SS} = 0.0 V)

Parameter	Symbol	Pin	Conditions	Value			Unit
				Min	Typ	Max	
Input frequency	f _{in}	XIN	—	12.0	—	55.0	MHz
Output frequency	f _{OUT}	ModOUT	—	12.0	—	55.0	MHz
Cycle-to-Cycle Jitter	t _{CJ}	ModOUT	Unloaded output with ADS OPEN @ 27 MHz		±150	±250	ps
Output clock duty cycle	t _{DCC}	ModOUT	Measured at V _{DD} / 2	45	50	55	%
Output Rise Time	t _r	ModOUT	between 20% to 80%		2.0		nS
Output Fall Time	t _f	ModOUT	between 80% to 20%		1.8		nS
Lock-up time	t _{LK}	ModOUT	Stable power supply, valid clock presented on XIN / CLKIN	—	—	3	ms

<Definition of modulation frequency and number of input clocks per modulation>

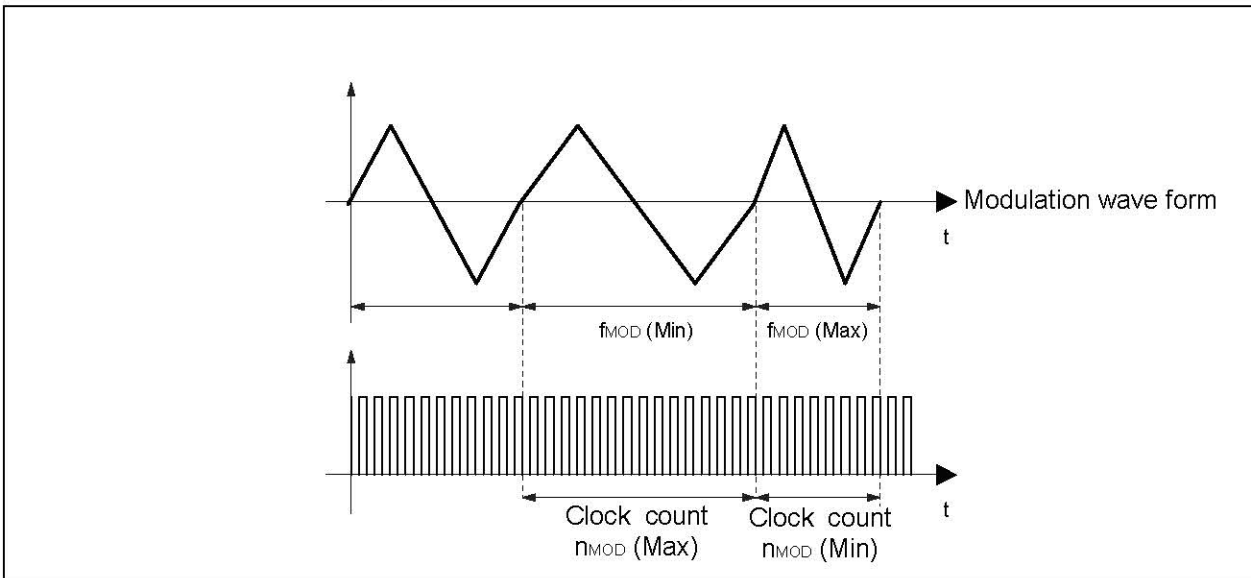

WAYCOI7368AG08CR contains the modulation period to realize the efficient EMI reduction.

The modulation period f_{MOD} depends on the input frequency and changes between $f_{MOD} (Min)$ and $f_{MOD} (Max)$.

Furthermore, the average value of f_{MOD} equals the typical value of the electrical characteristics.

■ OUTPUT CLOCK DUTY CYCLE ($t_{DCC} = t_b/t_a$)

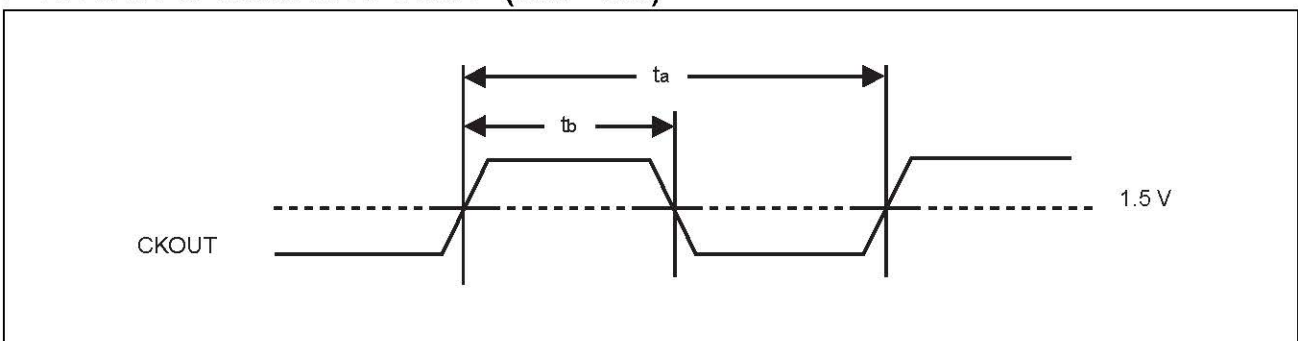

■ INPUT FREQUENCY ($f_{in} = 1/t_{in}$)

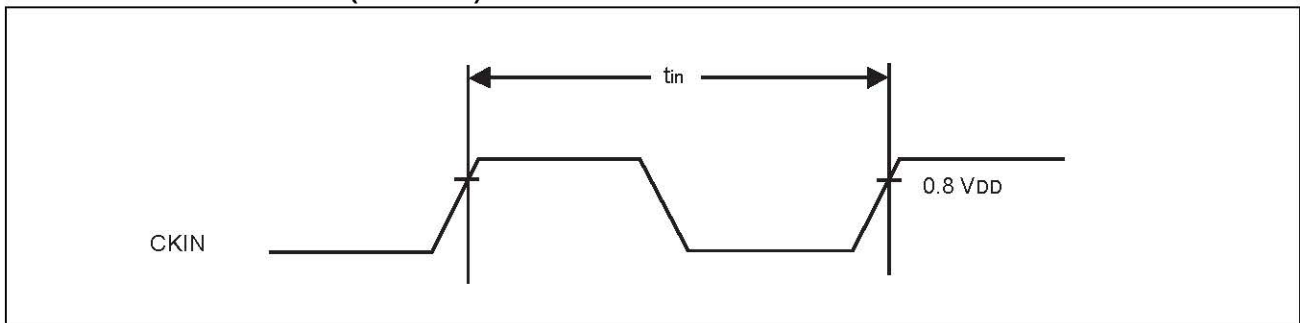

■ OUTPUT SLEW RATE (SR)

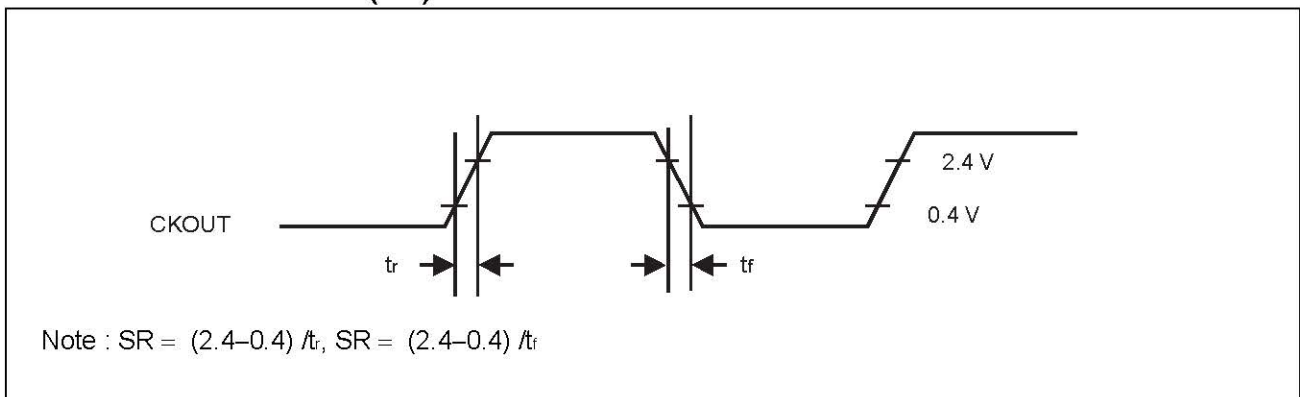

■ MODULATION WAVE FORM

- $\pm 1.5\%$ modulation rate, Example of center spread

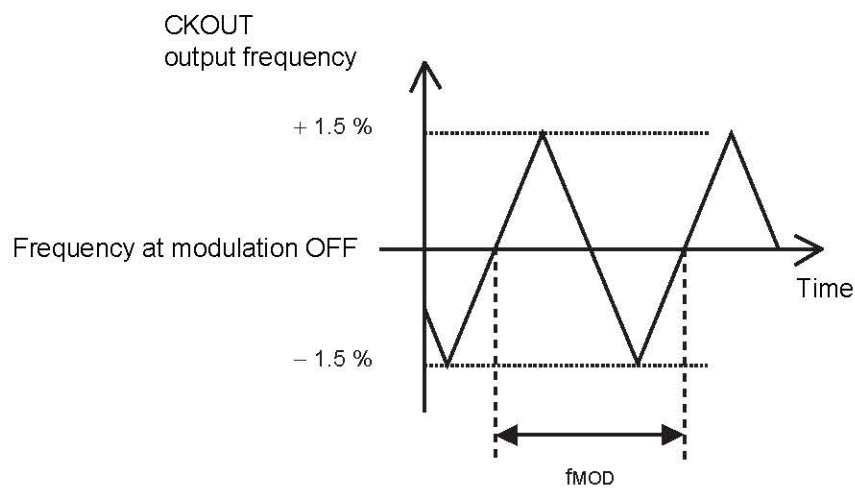

- -1.0% modulation rate, Example of down spread

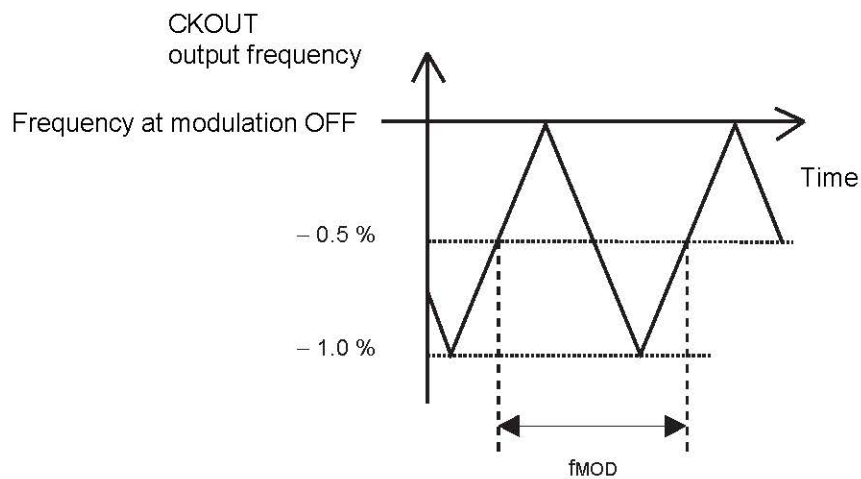

■ SPECTRUM EXAMPLE CHARACTERISTICS

The condition of the examples of the characteristic is shown as follows: Input frequency = 24 MHz (Output frequency = 24 MHz), use for WAYCOI7368AG08CR

Power-supply voltage = 3.3 V, None load capacity. Modulation rate = 1.5% (center spread).

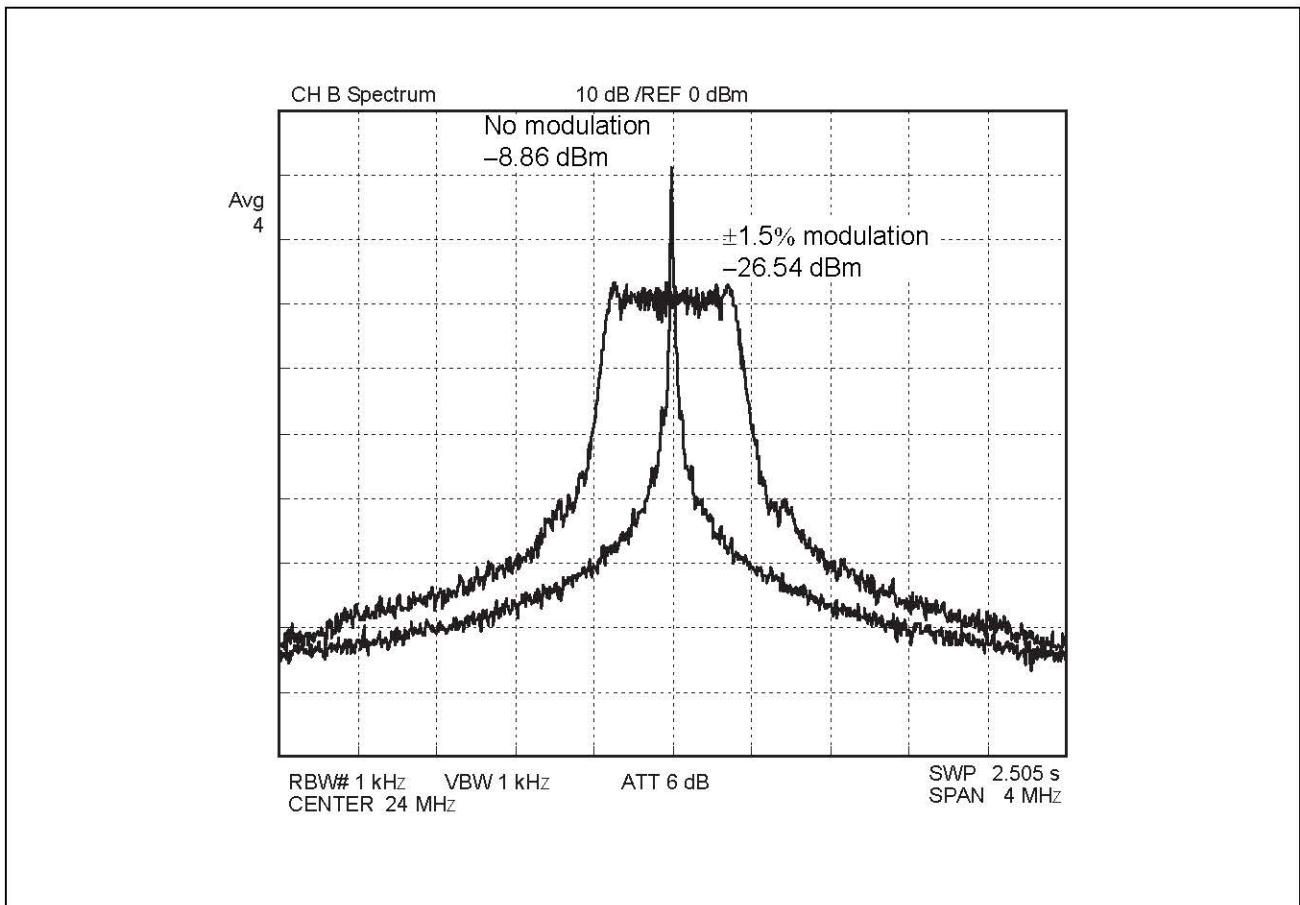

- Center spread

Spectrum is spread (modulated) by centering on the input frequency.

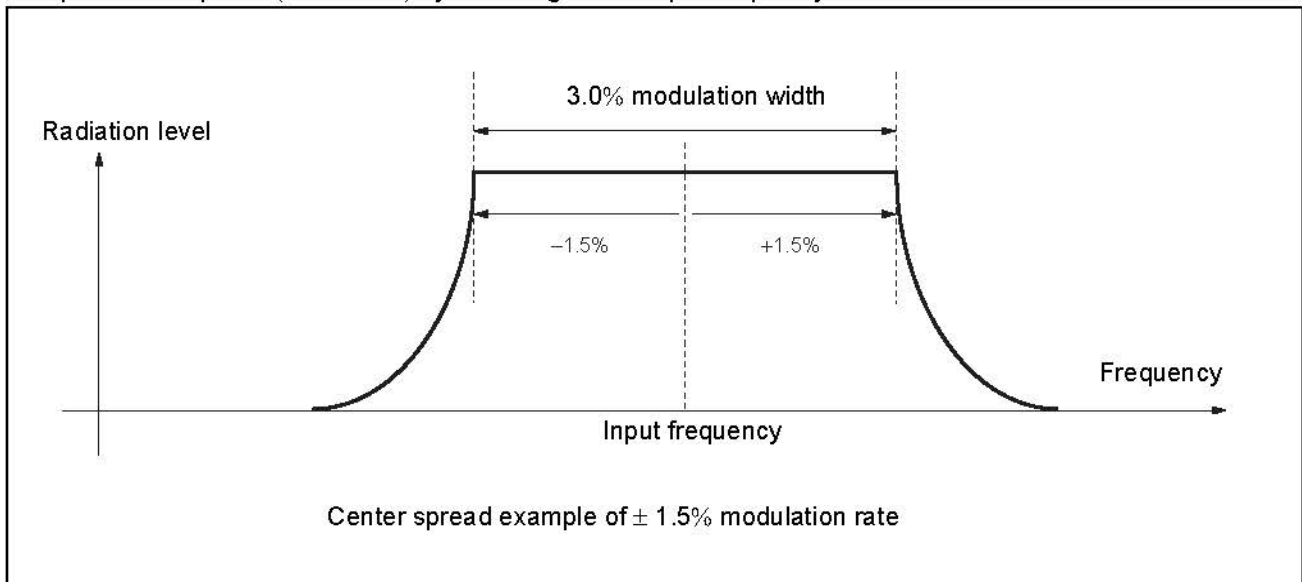

- Diagram of CLK spread

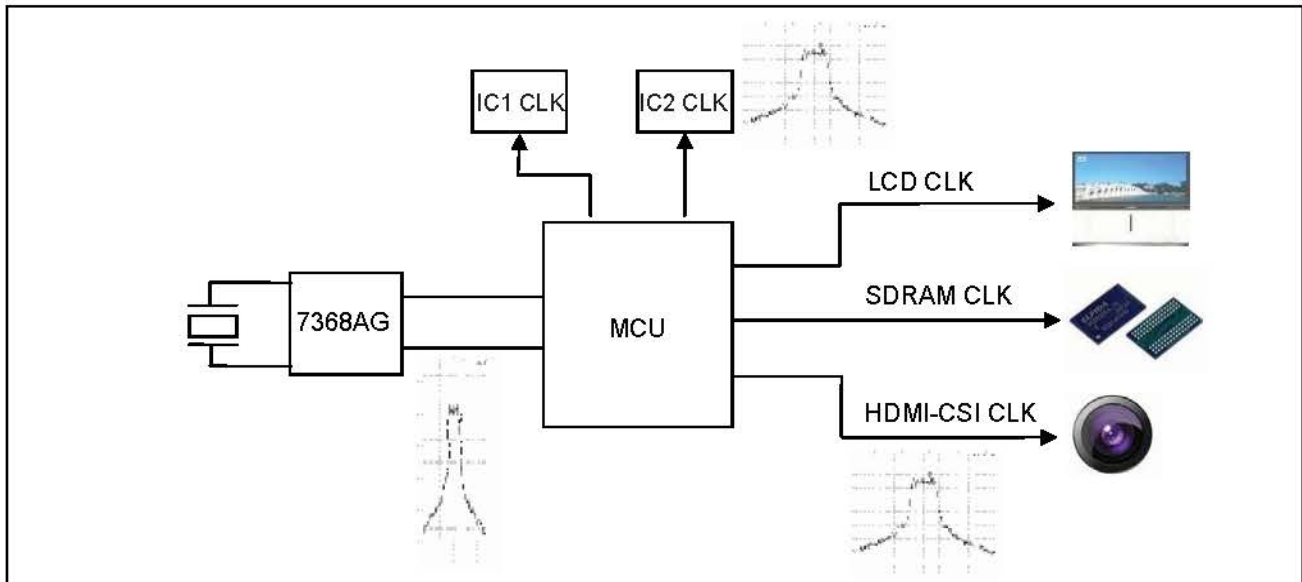

TDFN-2x2-8L

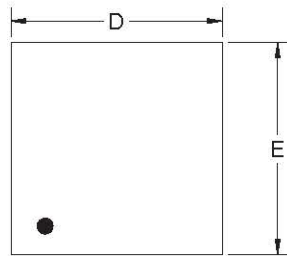

TOP VIEW

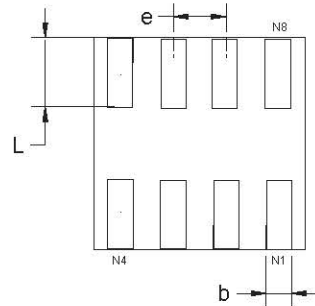

BOTTOM VIEW

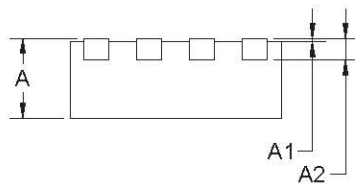

SIDE VIEW

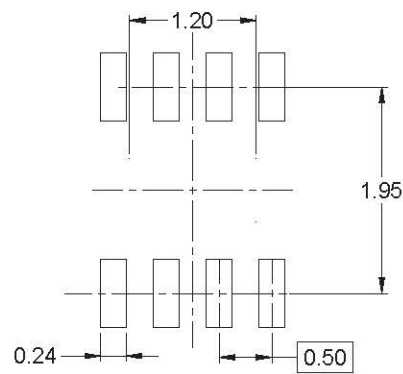

RECOMMENDED LAND PATTERN (Unit: mm)

Symbol	Dimensions In Millimeters		Dimensions In Inches	
	MIN	MAX	MIN	MAX
A	0.700	0.800	0.028	0.031
A1	0.000	0.050	0.000	0.002
A2	0.203 REF		0.008 REF	
D	1.900	2.100	0.075	0.083
E	1.900	2.100	0.075	0.083
b	0.180	0.300	0.007	0.012
L	0.500	0.600	0.020	0.024
e	0.500 TYP		0.020 TYP	

Ordering Code

Part Number	Package	Temperature
WAYCOI7368AG-08-CR	8- pin 2-mm TDFN COL - TAPE & REEL, Green	-40°C to +85 °C

Device Ordering Information

WAY COI 7368A G - 08 - C R

