

## DESCRIPTION

1108 Series is a clock generator for EMI (Electro Magnetic Interference) reduction. The peak of unnecessary (EMI) can be attenuated by making the oscillation frequency slightly modulate periodically with the internal modulator. 1108 Series accepts an input clock either from a fundamental Crystal or from an external reference (AC or DC coupled to XIN/CLKIN) and locks on to it delivering a 1x modulated clock output.

## FEATURE

- Power down pin : 4  $\mu$ A (Typ-sample) consumption current at power down
- Input frequency : 10.0 MHz to 134.0 MHz
- Output frequency : 10.0 MHz to 134.0 MHz (One-fold input frequency)
- Analog Deviation Selection
- Modulation clock output Duty : 40% to 60%
- Modulation clock Cycle\_Cycle Jitter : Less than 50 ps
- Power supply voltage : 2.5V--3.3 V
- Package : 8-pin TDFN
- Operating temperature : EMC73661108AF, 0°C to +70 °C  
EMC73661108AF, - 40 °C to +85 °C

## Application

EMC73661108 series is targeted for consumer electronics application such as MFP, STB, DSC, MID,HDMI,LCD panel Camcorder,and other timing sensitive analog video imaging applications Applications of HDMI, RJ45 port has good compatibility

## Typical Circuits Protection

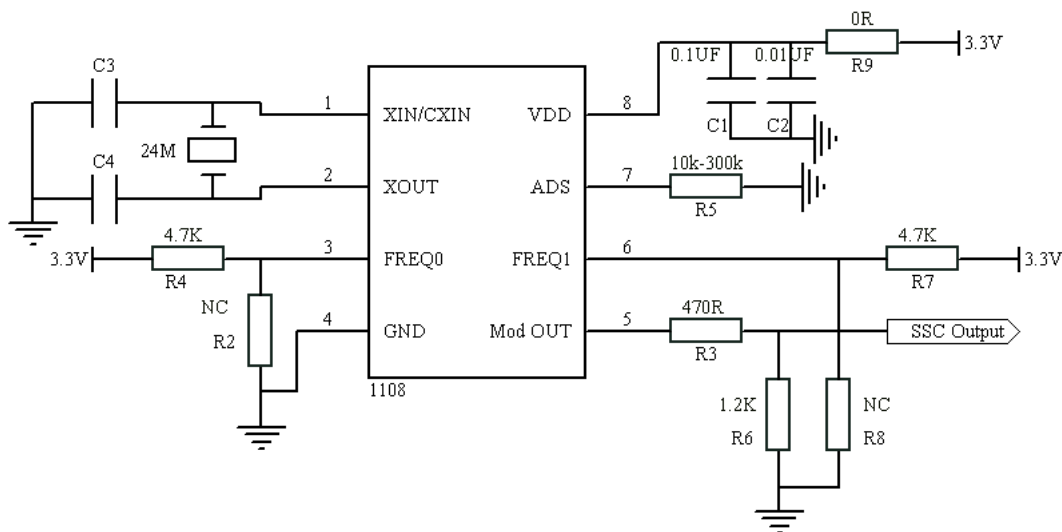

■ BLOCK DIAGRAM

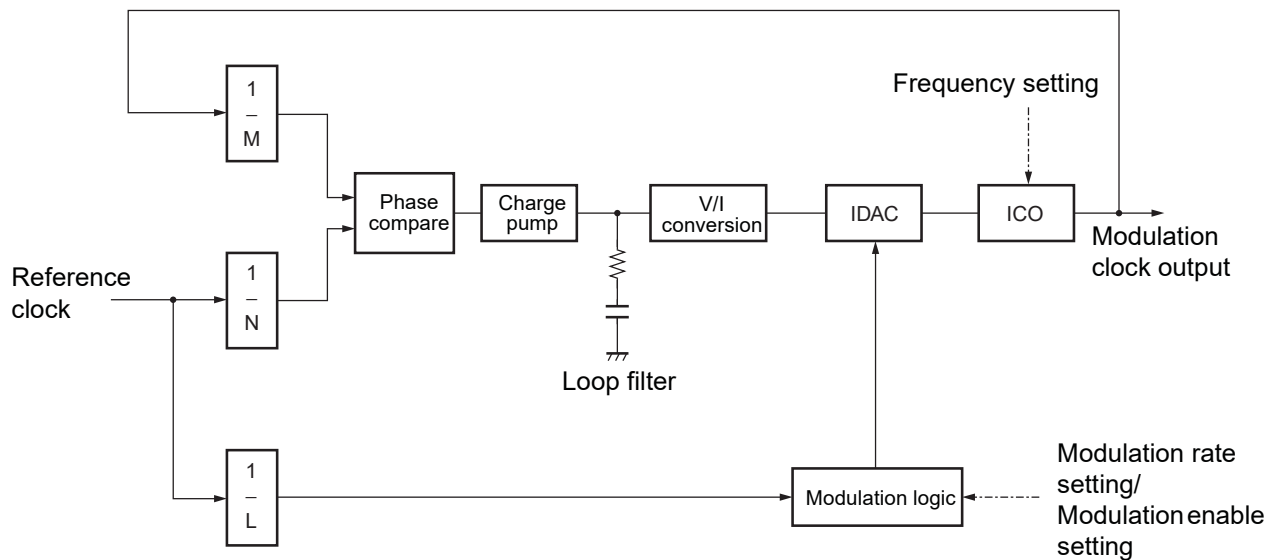
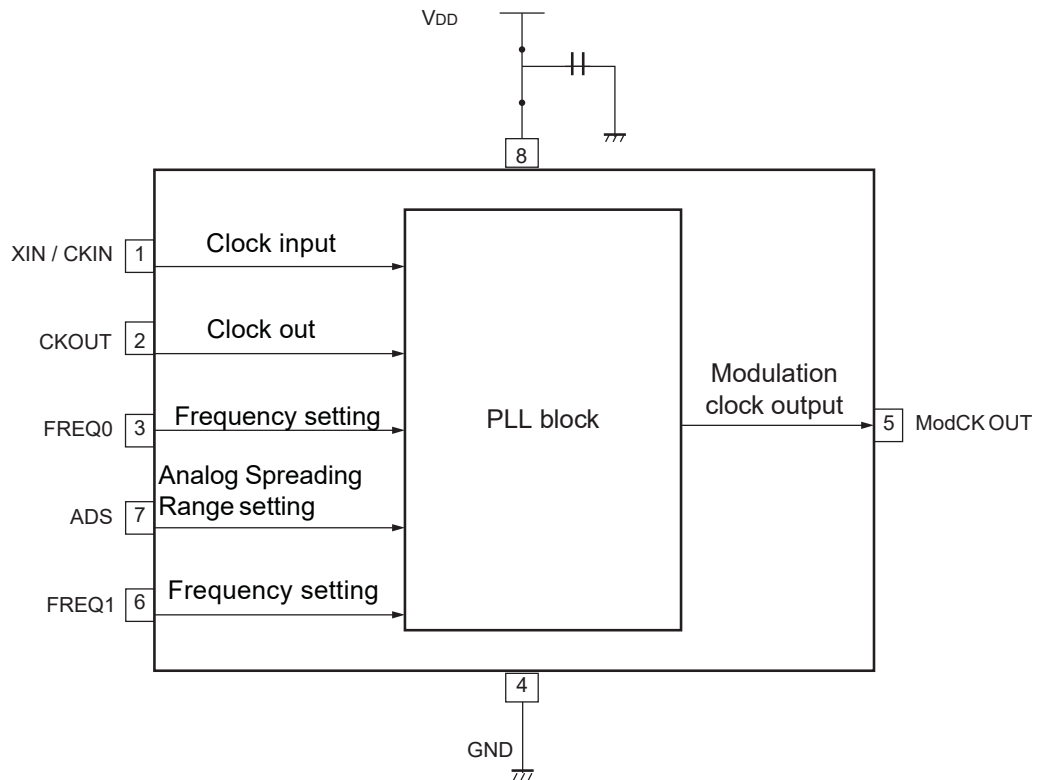

EMC73661108F PLL block

A glitchless IDAC (current output D/A converter) provides precise modulation, thereby dramatically reducing EMI.

## ■ PIN ASSIGNMENT

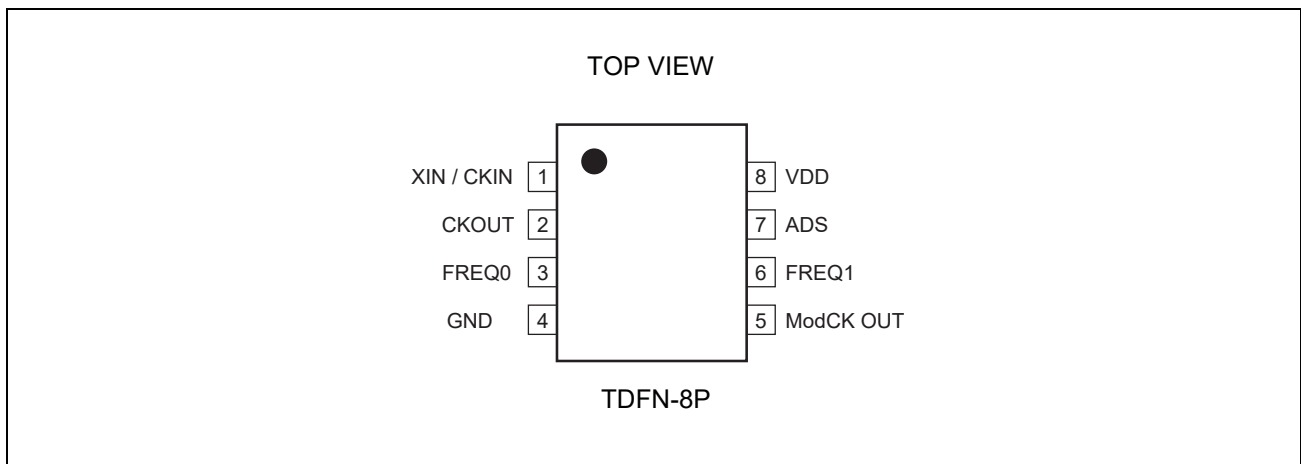

## ■ PIN DESCRIPTION

Pin name	I/O	Pin no.	Description
XIN / CKIN	I	1	Clock input pin (or External reference clock input).
CKOUT	I	2	Crystal connection( external reference, this pin should be left open)
FREQ0	I	3	Frequency setting pin
GND	---	4	GND pin
ModCK OUT	O	5	Modulation clock output
FREQ1	I	6	Frequency setting pin
ADS	I	7	Spreading Range Selection through external resistor to GND.
VDD	---	8	Power supply voltage pin

## ■ PIN SETTING

When changing the pin setting, the stabilization wait time for the modulation clock required. The stabilization wait time for the modulation clock takes the maximum value of Lock-Up time in “■ ELECTRICAL CHARACTERISTICS • AC Characteristics”.

### ADS modulation enable setting

Resistance(K ohm)	Spreading Range(+/-%)
0-800K	2.5 - 0.01
---	---

Note : Analog Spreading Range Selection through external resistor to GND.  
Spectrum is spread (modulated) by centering on the input frequency.

### FREQ0, FREQ1 frequency setting

FREQ0	FREQ1	Input frequency range
H	H	10 MHz to 30 MHz
L	H	66 MHz to 134 MHz
H	L	20 MHz to 67 MHz
L	L	40 MHz to 80 MHz

Note : It is set according to the frequency of the clock input to the device. Set FREQ0 pin to “H” for the pin opened because FREQ0 pin has pull-up resistor.

## ■ ABSOLUTE MAXIMUM RATINGS

Parameter	Symbol	Rating		Unit
		Min	Max	
Power supply voltage*	$V_{DD}$	- 0.5	+ 4.0	V
Input voltage*	$V_I$	$V_{SS} - 0.5$	$V_{DD} + 0.5$	V
Output voltage*	$V_O$	$V_{SS} - 0.5$	$V_{DD} + 0.5$	V
Storage temperature	$T_{ST}$	- 55	+ 125	°C
Operation junction temperature	$T_J$	0	+70	°C
Output current	$I_O$	2	4	mA
Overshoot	$V_{IOVER}$	—	$V_{DD} + 1.0$ ( $t_{OVER} \leq 4\text{ns}$ )	V
Undershoot	$V_{IUNDER}$	$V_{SS} - 1.0$ ( $t_{UNDER} \leq 4\text{ns}$ )	—	V

\* : The parameter is based on  $V_{SS} = 0.0\text{ V}$ .

**WARNING:** Semiconductor devices can be permanently damaged by application of stress (voltage, current, temperature, etc.) in excess of absolute maximum ratings. Do not exceed these ratings.

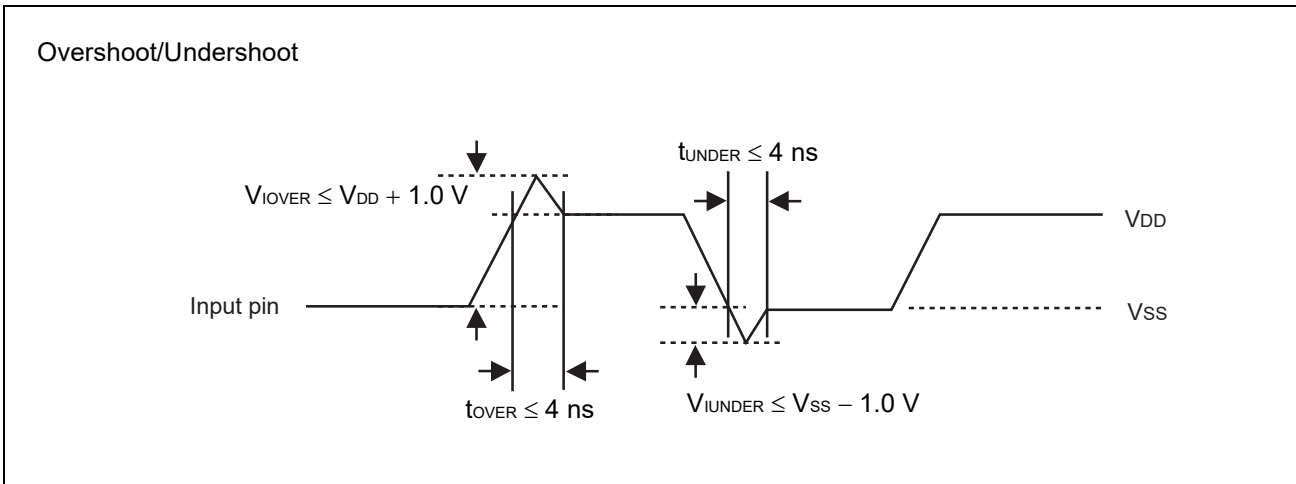

## ■ ELECTRICAL CHARACTERISTICS

### • DC Characteristics

(Ta = 0 °C to +70 °C, V<sub>DD</sub> = 3.3 V ± 0.3 V, V<sub>SS</sub> = 0.0 V)

Parameter	Symbol	Pin	Conditions	Value			Unit
				Min	Typ	Max	
Output voltage	V <sub>OH</sub>	CKOUT	"H" level output I <sub>OH</sub> = -4 mA	V <sub>DD</sub> - 0.5	—	V <sub>DD</sub>	V
	V <sub>OL</sub>	CKOUT	"L" level output I <sub>OL</sub> = 4 mA	V <sub>SS</sub>	—	0.4	V
Output impedance	Z <sub>o</sub>	CKOUT	10 MHz to 134 MHz	—	35	—	Ω
Input capacitance	C <sub>IN</sub>	CKIN, FREQ0, FREQ1,	Ta = +25 °C, V <sub>DD</sub> = V <sub>I</sub> = 0.0 V, f = 1 MHz	—	—	16	pF
Load capacitance	C <sub>L</sub>	CKOUT	10 MHz to 30 MHz	—	—	10	pF
			30MHz to 100 MHz	—	—	15	
			100 MHz to 134 MHz	—	—	7	
Input Pull-up resistance	R <sub>PUE</sub>	FREQ0	V <sub>IL</sub> = 0.0 V	25	50	200	kΩ
	--	--		--	--	--	
Power supply current	I <sub>CC</sub>	V <sub>DD</sub>	No load capacitance at 27 MHz output	—	2.0	4	mA
Power down current	I <sub>pd</sub>	V <sub>DD</sub>	Input clock stopping	—	4	—	μA

### • AC Characteristics

(Ta = 0 °C to +70 °C, V<sub>DD</sub> = 3.3 V ± 0.3 V, V<sub>SS</sub> = 0.0 V)

Parameter	Symbol	Pin	Conditions	Value			Unit
				Min	Typ	Max	
Input frequency	f <sub>in</sub>	CKIN	—	10.0	—	134	MHz
Output frequency	f <sub>OUT</sub>	CKOUT	—	10.0	—	134	MHz
Output slew rate	SR	CKOUT	Load capacitance 15 pF 0.4 V to 2.4 V	0.4	—	4.0	V/ns
Output clock duty cycle	t <sub>DCC</sub>	CKOUT	1.5 V	40	—	60	%
Output Rise Time			between 20% to 80%		2.2		nS
Output Fall Time			between 80% to 20%		2.0		nS

(Continued)

( $T_a = 0\text{ }^{\circ}\text{C}$  to  $+70\text{ }^{\circ}\text{C}$ ,  $V_{DD} = 3.3\text{ V} \pm 0.3\text{ V}$ ,  $V_{SS} = 0.0\text{ V}$ )

Parameter	Symbol	Pin	Conditions	Value			Unit
				Min	Typ	Max	
Lock-up time	$t_{LK}$	CKOUT	10.0 MHz to 80 MHz	—	2	5	ms
			80 MHz to 134 MHz	—	3	8	
Cycle-cycle jitter	$t_{JC}$	CKOUT	No load capacitance, $T_a = +25\text{ }^{\circ}\text{C}$ , $V_{DD} = 3.3\text{ V}$	—	—	50	ps-rms

Note : The modulation clock stabilization wait time is required after the power is turned on, the IC recovers from power saving, or after **FREQ** (frequency range) or **ENS** (modulation ON/OFF) setting is changed. For the modulation clock stabilization wait time, assign the maximum value for lock-up time.

### <Definition of modulation frequency and number of input clocks per modulation>

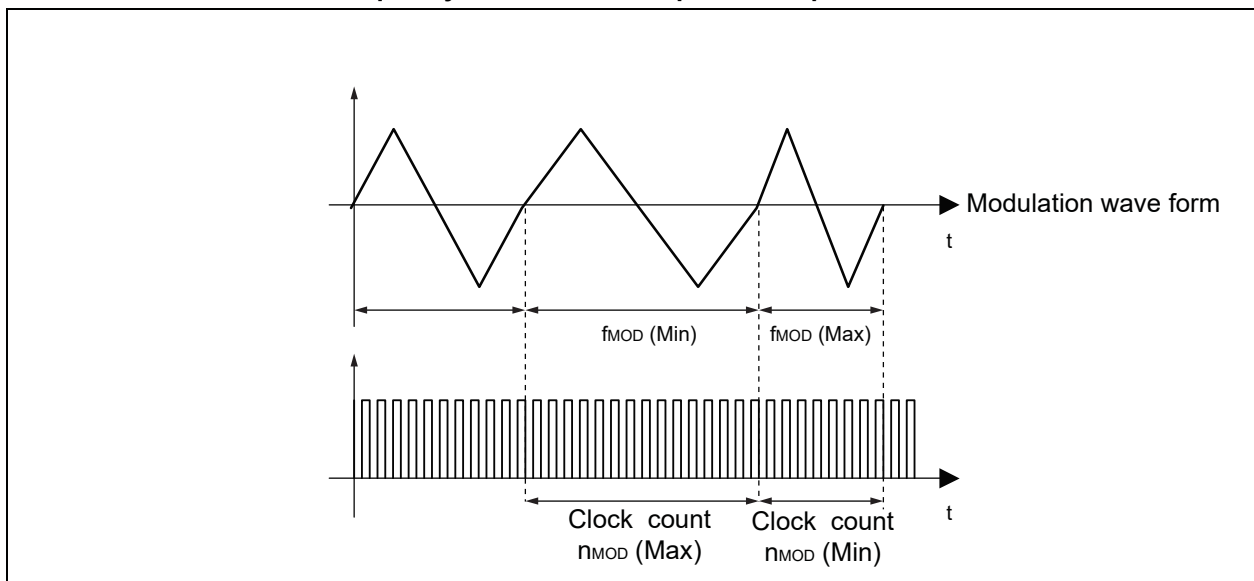

EMC73661108F contains the modulation period to realize the efficient EMI reduction.

The modulation period  $f_{MOD}$  depends on the input frequency and changes between  $f_{MOD}(\text{Min})$  and  $f_{MOD}(\text{Max})$ .

Furthermore, the average value of  $f_{MOD}$  equals the typical value of the electrical characteristics.

■ OUTPUT CLOCK DUTY CYCLE ( $t_{DCC} = t_b/t_a$ )

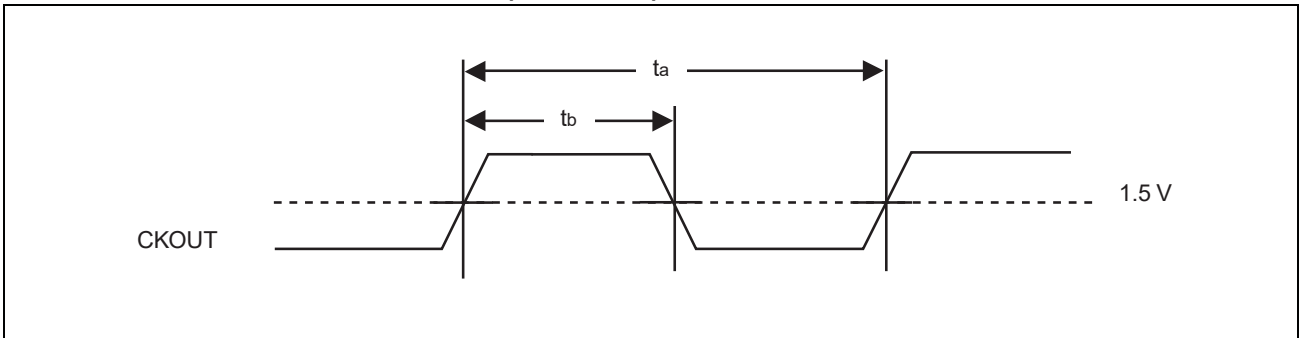

■ INPUT FREQUENCY ( $f_{in} = 1/t_{in}$ )

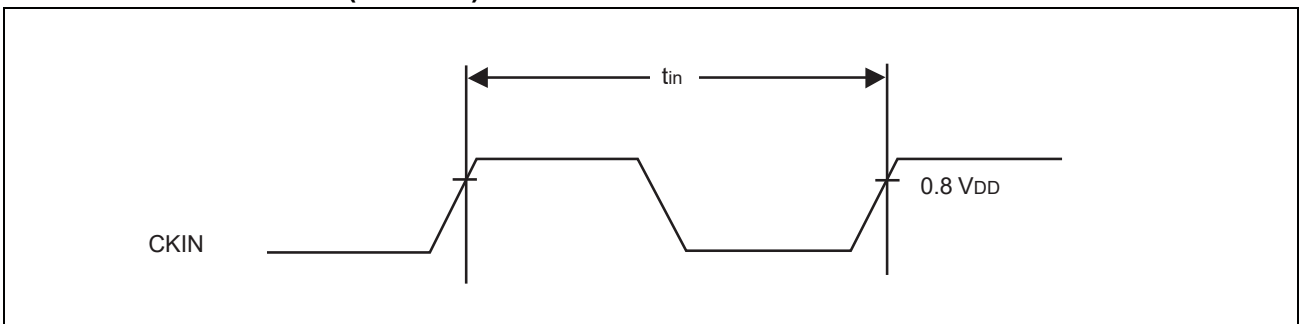

■ OUTPUT SLEW RATE (SR)

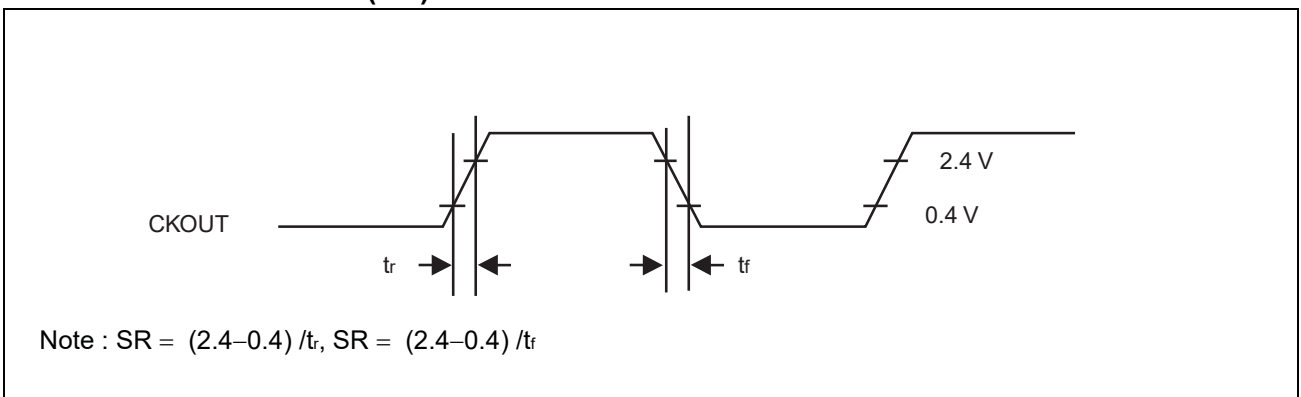



## ■ MODULATION WAVE FORM

- $\pm 1.5\%$  modulation rate, Example of center spread

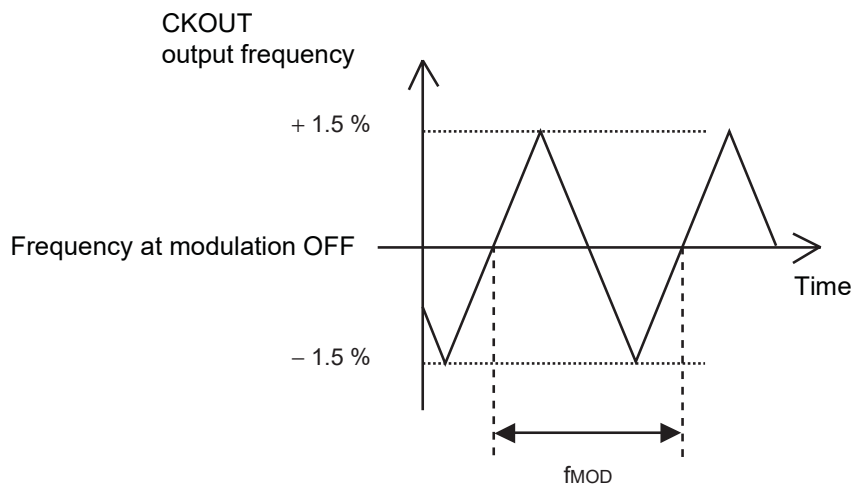

- $-1.0\%$  modulation rate, Example of down spread

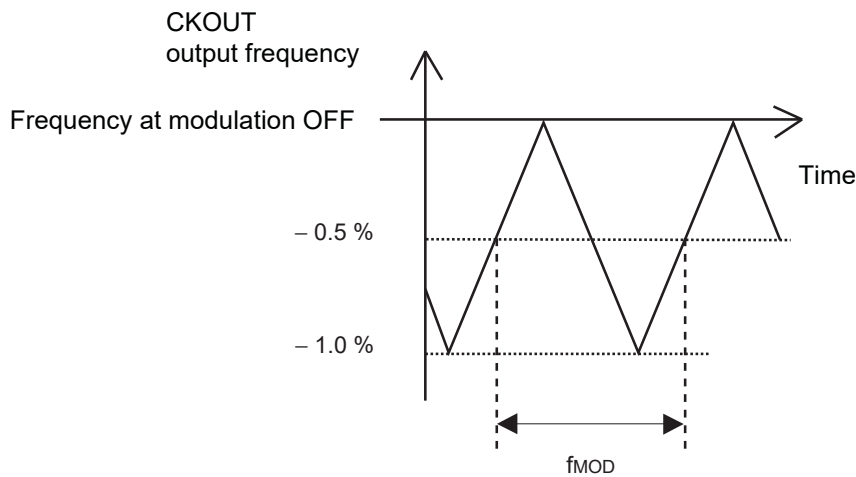

## ■ SPECTRUM EXAMPLE CHARACTERISTICS

The condition of the examples of the characteristic is shown as follows: Input frequency = 24 MHz (Output frequency = 24 MHz), use for EMC73661108F

Power-supply voltage = 3.3 V, None load capacity. Modulation rate = 1.5% (center spread).

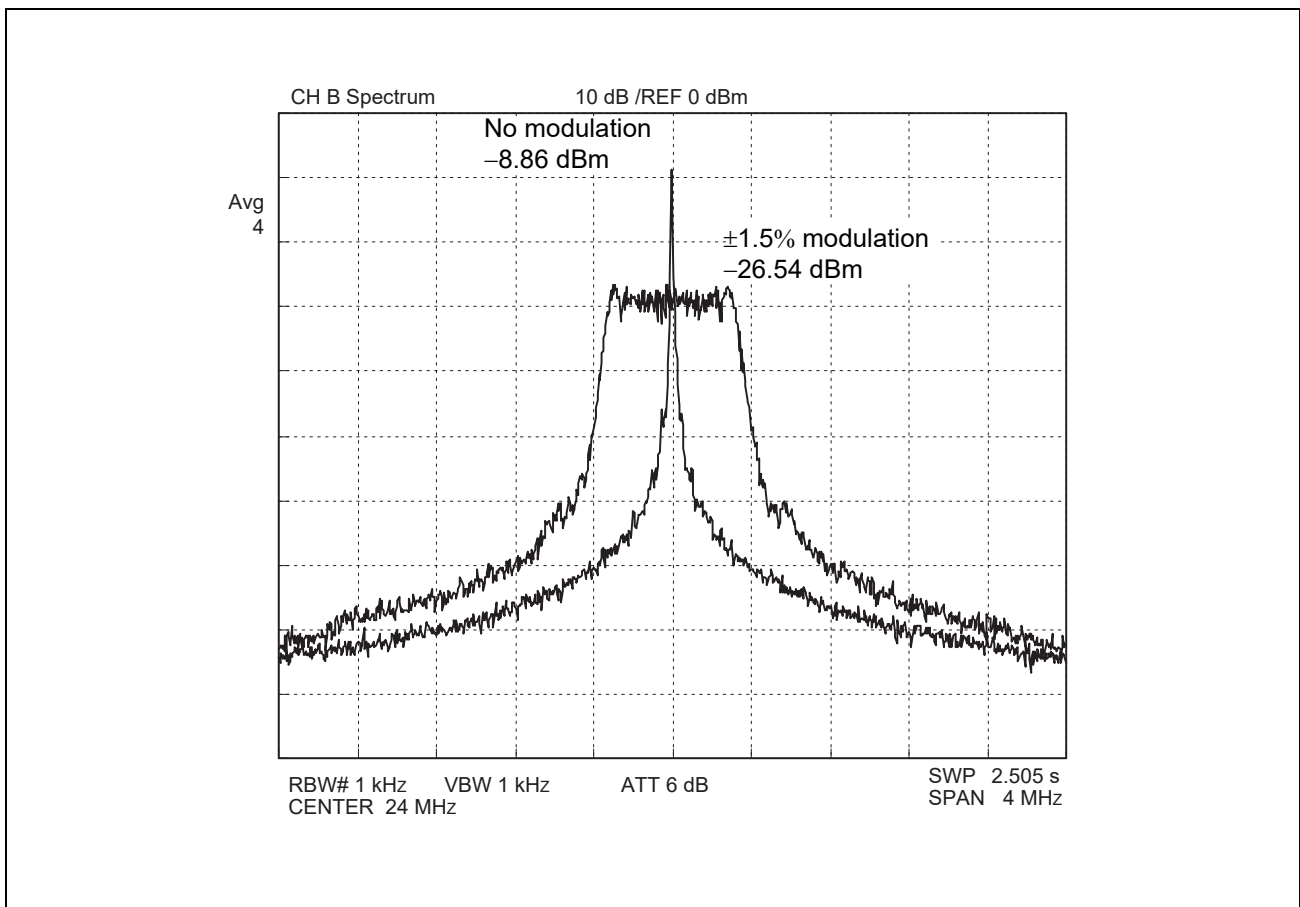

- Center spread

Spectrum is spread (modulated) by centering on the input frequency.

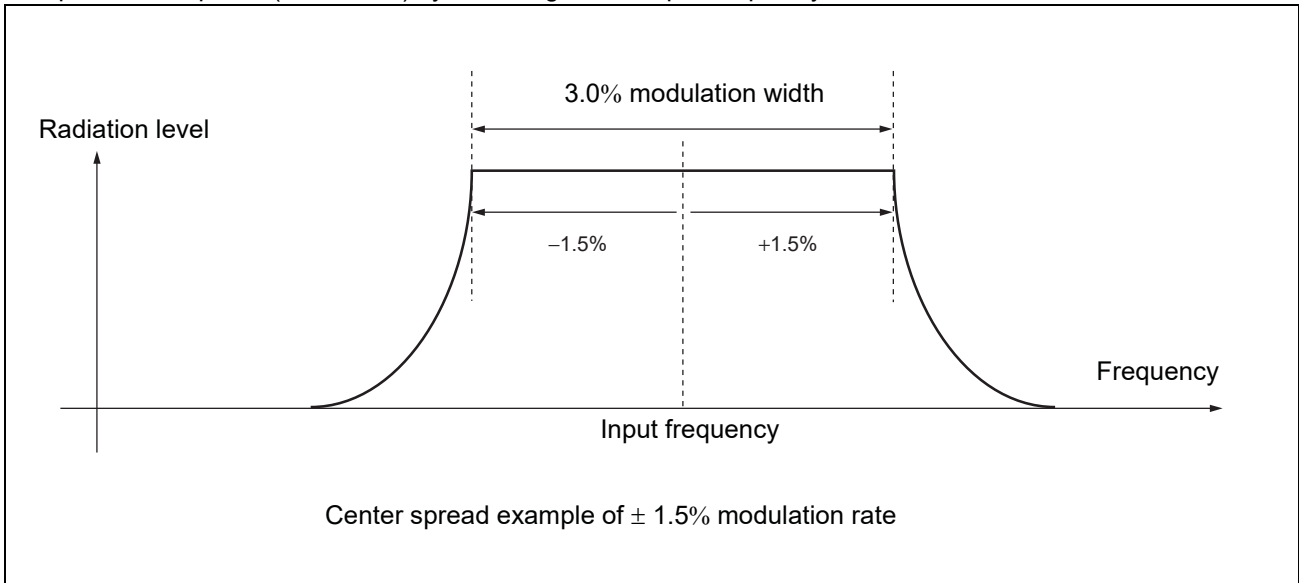

- Diagram of CLK spread

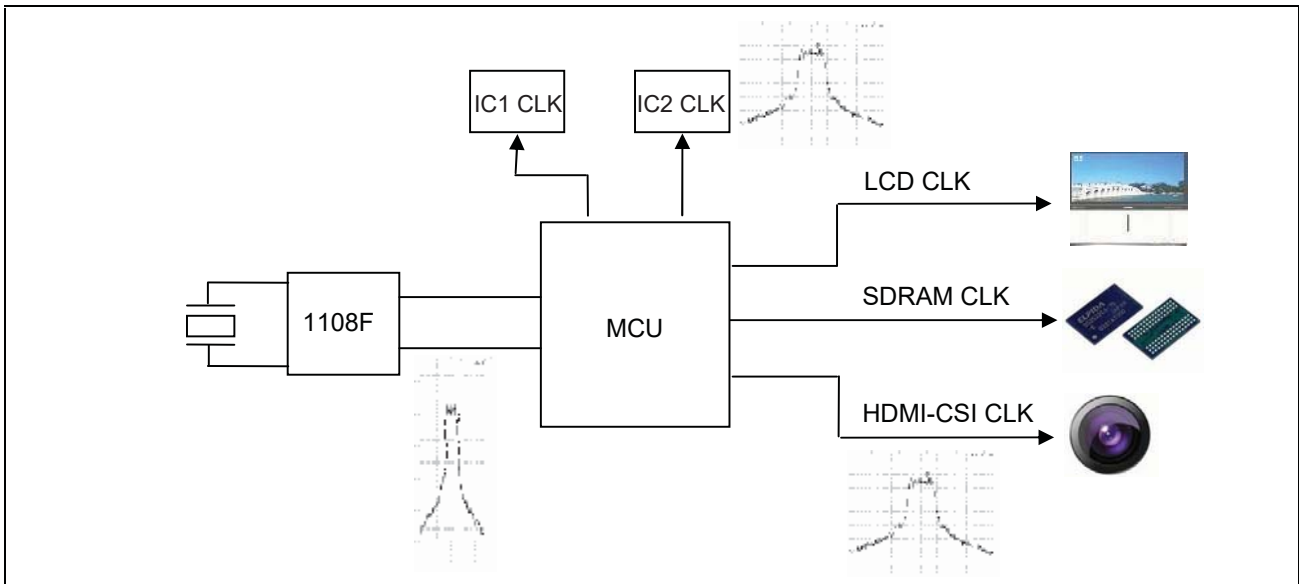

## TDFN-2x2-8L

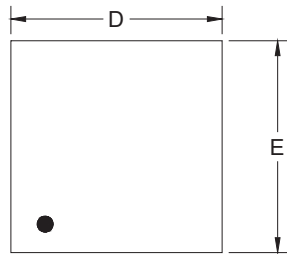

TOP VIEW

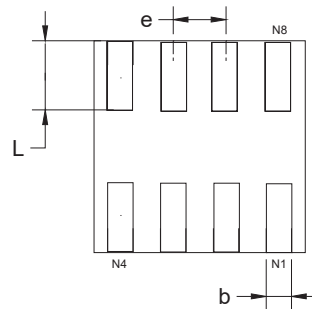

BOTTOM VIEW

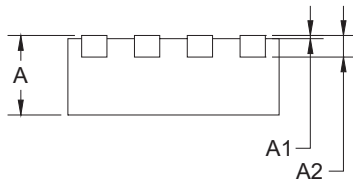

SIDE VIEW

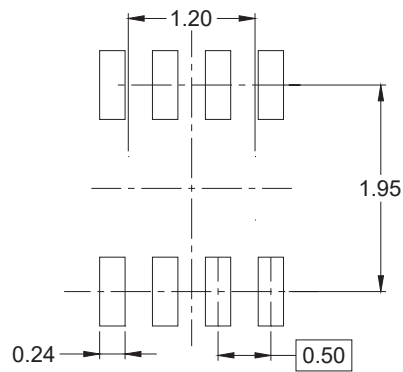

RECOMMENDED LAND PATTERN (Unit: mm)

Symbol	Dimensions In Millimeters		Dimensions In Inches	
	MIN	MAX	MIN	MAX
A	0.700	0.800	0.028	0.031
A1	0.000	0.050	0.000	0.002
A2	0.203 REF		0.008 REF	
D	1.900	2.100	0.075	0.083
E	1.900	2.100	0.075	0.083
b	0.180	0.300	0.007	0.012
L	0.500	0.600	0.020	0.024
e	0.500 TYP		0.020 TYP	

### Ordering Code

Part Number	Package	Temperature
EMC73661108F-08-CT	8- pin 2-mm TDFN COL - TAPE & REEL, Green	0°C to +70 °C

### Device Ordering Information

