

SPECIFICATION FOR APPROVAL

ROHS



CUSTOMER :

CUSTOMER P/N. :

WD P/N. : WDSQ1918L-20MH MIN

ITEM : COIL

ISSUED NO. (REV.) : 00

ISSUED DATE : 2021.01.21

FILE NO. :

CUSTOMER APPROVAL

APPROVED	CHECKED	DESIGNED
叶鑫	陈安鸿	王萍

广州葆诚技术有限公司

ADDRESS : Room No.819 R&D building, No.3 Guangpu West Road, Guangzhou.

地 址 : 广州开发区光谱西路3号研发厂房819房

TEL : 020-28186136/18028017279

E-mail : 4335539@qq.com

SPECIFICATION FOR APPROVAL

1.DIMENSIONS: (UNIT: mm)

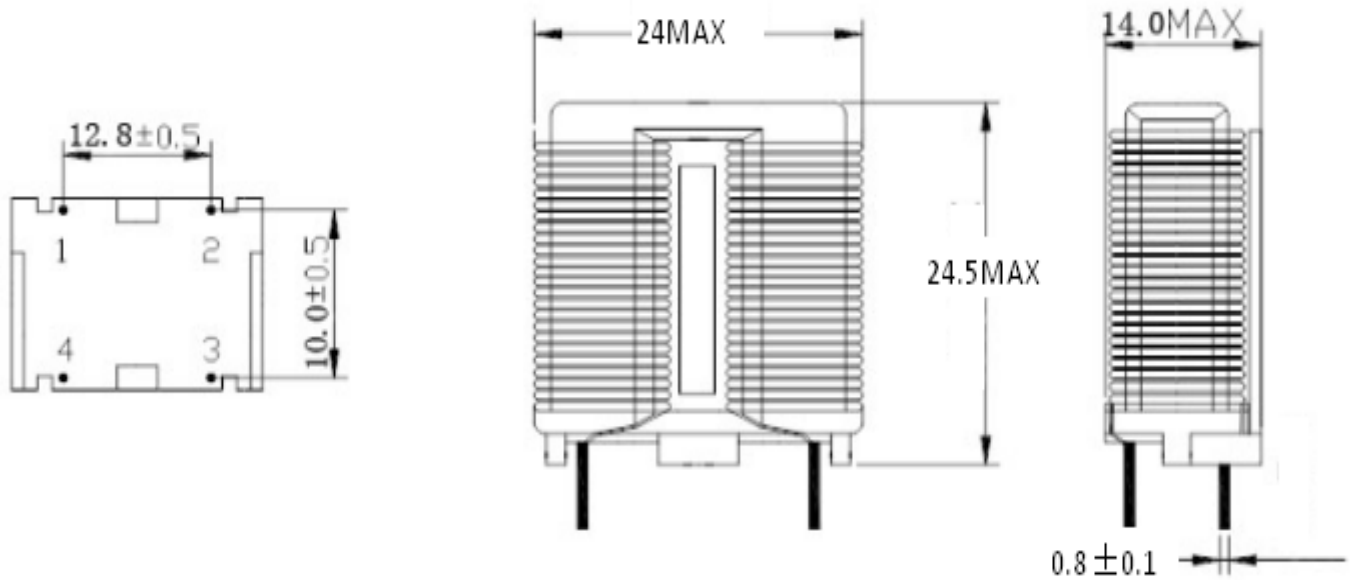

Note:Varnish impregnated.

The same side line, the same side outlet.□

2.SCHEMATICS:



Customer	SKYRC	Version no.	Date:	Page No.
		00	2021.01.21	2/3
	QA	APPROVED	CHECKED	DESIGNED
WD P/N.	李长江	叶鑫	陈安鸿	王萍
WDSQ1918L-20MH N				

SPECIFICATION FOR APPROVAL

3.WINDING SPECIFICATION:

Winding	Terminal		Wire Size mm	Winding Turns	UL Tape Ts/mm/mil	Winding Fashion
	Start	Finish				
N1	1	4	ø0.15*1.0mm 2UEW	63Ts ref		Close
N2	2	3	ø0.15*1.0mm 2UEW	63Ts ref		Close

4.ELECTRICAL CHARACTERISTICS:

4.1.Inductance Test: @1KHz 0.25Vr.m.s (CH-1062) AT: 25°C

L(1-4&2-3)=20mH MIN

4.2.Dc Resistance: @25°C (YD-2511)

R(1-4&2-3)=250mΩ MAX

4.3.Hi-Pot Test: @50Hz (YD2670)

N1-N2 1500Vac 5mA 3Sec

5.MATERIALS LISE:

ITEM	SIZE	PART & MATERIAL	MANUFACTURER	UL TEMP	UL FILE NO.
CORE	FT12C/KA120	Mn-Zn	JIU XIN/ GUANG DA/ ACME	155°C	
WIRE	1or2UEW-1.0*0.15mm	Polyurethane	Shandong Pengtai Stock Co., Ltd	180°C	
		Enamelled Wire 2uew	Well Ascent Electronic (ganzhou) co.,Ltd		
			GuanDong RongSen		
BOND	D-800	Epoxy	Zhi Li Quang	130°C	
BASE	T375HF T200HF		Chang Chun Plastics Co., Ltd	130°C	
SOLDER	Sn99.3Cu0.7	Sn+Cu	Xi Da		
Customer		Version no.	Date:	Page No.	
		00	2021.01.21	3/3	
P/N	QA	APPROVED	CHECKED	DESIGNED	
WD P/N.	李长江	叶鑫	陈安鸿	王萍	
WDSQ1918L-20MH MIN					